

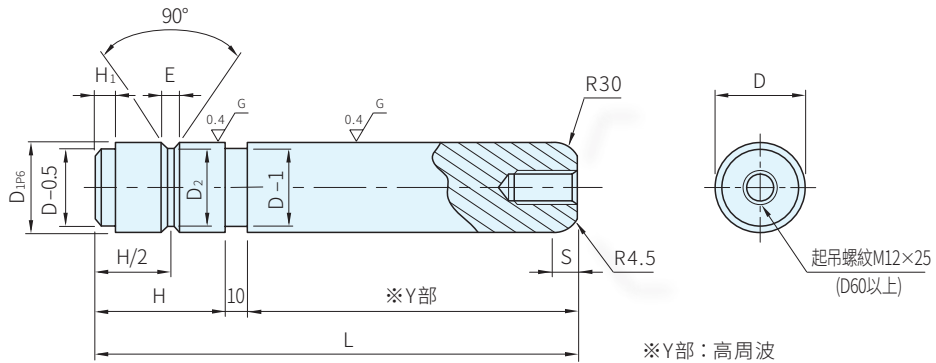

材質	硬度
S45C	HR55~(高周波)



D	D _{1P6}	D ₂	H	E	S	H ₁	品號		L	庫存
							TYPE	D		
25	-0.005 -0.015	25	21	30	8	5	HSN	25	80	•
									100	•
									120	•
									140	•
									160	•
30	30	26	40	10	10	100			•	
						120			•	
						140			•	
						160			•	
40	40	36	50	8	5	180			•	
						200	•			
						250	•			
50	50	45	70	10	10	120	•			
						140	•			
						160	•			
						180	•			
						200	•			
60	60	55	90	12	10	200	•			
						220	•			
						250	•			
						300	•			
						350	•			
65	65	60	100	12	10	250	•			
						300	•			
						350	•			
80	80	75	120	12	10	250	•			
						300	•			
						350	•			
						400	•			
						450	•			
100	100	95	150	12	10	300	•			
						350	•			
						400	•			
						450	•			
						500	•			

追加 追加工

變更	Code	變更內容
	LC	變更導柱長度 L _{min.} ≤ LC < L 指定單位1mm D ≤ 50適用
	MC	固定側部螺紋加工

PS 備註

・LC長度加工，MC攻牙
追加工，亦可製作

訂貨： - - (MC)

- HSN30 - LC90 (變更導柱長度)
- HSN60 - 200 - MC (固定側部螺紋加工)
- HSN40 - LC110 - MC (變更導柱長度+固定側部螺紋加工)

交期： 天

訂貨： - 交期： 天

HSN80 - 300